

AROMA®

Instruction Manual 3-in-1 Grillet™

For Model Numbers:
ASP-238
ASP-238B



**Questions or concerns
about your 3-in-1 Grillet™?**

*Before returning to the
store...*



Aroma's customer service
experts are happy to help.
Call us toll-free at
1-800-276-6286.



Answers to many common
questions and even
replacement parts can
be found online. Visit
[www.AromaCo.com/Support.](http://www.AromaCo.com/Support)





Congratulations on purchasing your Aroma® 3-in-1 Grillet™. This versatile appliance is an indoor grill, slow cooker and steamer all in one!

The Aroma® 3-in-1 Grillet™ gives your food that desired grilled flavor in the comfort of your own kitchen. Now you can enjoy the taste of summer all year round as you prepare burgers, hot dogs, steak, shish kabobs, chicken, lamb and more. The removable temperature control probe sets up to 450° F, heating quickly and evenly thanks to the cast aluminum cooking pot. The grill's ridge surface also provides a healthier way to cook as it channels away excess fat for delicious, leaner meals. Its large 4-quart capacity and tempered glass lid make it perfect for slow cooking homemade favorites like tender roasts, delicious chili and savory stews. Or simply steam your meats and vegetables, locking in the flavor and nutrients for an easy and healthy meal. The Aroma® 3-in-1 Grillet™'s unique versatility makes it a hero of home cooking!

For more information on your Aroma® 3-in-1 Grillet™, or for product service, replacement parts and other home appliance solutions, please visit us online at www.AromaCo.com.

See what's cooking with Aroma® online!



www.AromaTestKitchen.com



www.facebook.com/AromaHousewares



www.twitter.com/AromaHousewares



Published By:
Aroma Housewares Co.
6469 Flanders Drive
San Diego, CA 92121, U.S.A.
1-800-276-6286
www.AromaCo.com
©2013 Aroma Housewares Company
All rights reserved.





IMPORTANT SAFEGUARDS

Basic safety precautions should always be followed when using electrical appliances, including the following:

1. Important: Read all instructions carefully before first use.

2. Do not touch hot surfaces. Use handles or knobs.
3. To protect against fire, electrical shock and injury to persons, do not immerse cord, plug or the appliance in water or any other liquid.
4. Close supervision is necessary when any appliance is used by or near children.
5. Unplug from outlet when not in use and before cleaning. Allow the appliance to cool before putting on or taking off parts and before cleaning the appliance.
6. Do not operate any appliance with a damaged cord or plug or after the appliance malfunctions or has been damaged in any manner. Contact Aroma® customer service for examination, repair or adjustment.
7. The use of accessory attachments not recommended by Aroma® Housewares may result in fire, electric shock or injury.
8. Do not use outdoors.
9. Do not let the power cord touch hot surfaces or hang over the edge of the counter or table.
10. Do not place on or near a hot burner or in a heated oven.
11. Extreme caution must be used when using or moving the appliance while containing hot oil or other hot liquids.
12. Do not use the appliance for other than its intended use.
13. Always attach the plug to the appliance first, and then plug the cord into the wall outlet. To disconnect, turn any control to "OFF" then remove the plug from the wall outlet.
14. Use only on a dry, level and heat-resistant surface.
15. This appliance should be operated on a separate electrical circuit from other operating appliances. If the electrical circuit is overloaded with other appliances, this appliance may not operate properly.
16. Use only the thermostatically controlled appliance plug of type CTW300A (2-conductor, Manufactured by Kaikai Electric Appliances Co Ltd) when operating this appliance
17. This appliance is not intended for deep frying food.

SAVE THESE INSTRUCTIONS



IMPORTANT SAFEGUARDS

Short Cord Instructions

1. A short power-supply cord is provided to reduce the risks resulting from becoming entangled in or tripping over a longer cord.
2. Longer extension cords are available and may be used if care is exercised in their use.
3. If a longer extension cord is used:
 - a. The marked electrical rating of the extension cord should be at least as great as the electrical rating of the appliance.
 - b. The longer cord should be arranged so that it will not drape over the counter top or tabletop where it can be pulled by children or tripped over unintentionally.



Polarized Plug

This appliance has a **polarized plug** (one blade is wider than the other); follow the instructions below:

To reduce the risk of electric shock, this plug is intended to fit into a polarized outlet only one way. If the plug does not fit fully into the outlet, reverse the plug. If it still does not fit, contact a qualified electrician. Do not attempt to modify the plug in any way.

If the supply cord is damaged, it must be replaced by the manufacturer, its service agent or a similarly qualified person in order to avoid a hazard.

THIS APPLIANCE IS FOR HOUSEHOLD USE ONLY.



PARTS IDENTIFICATION

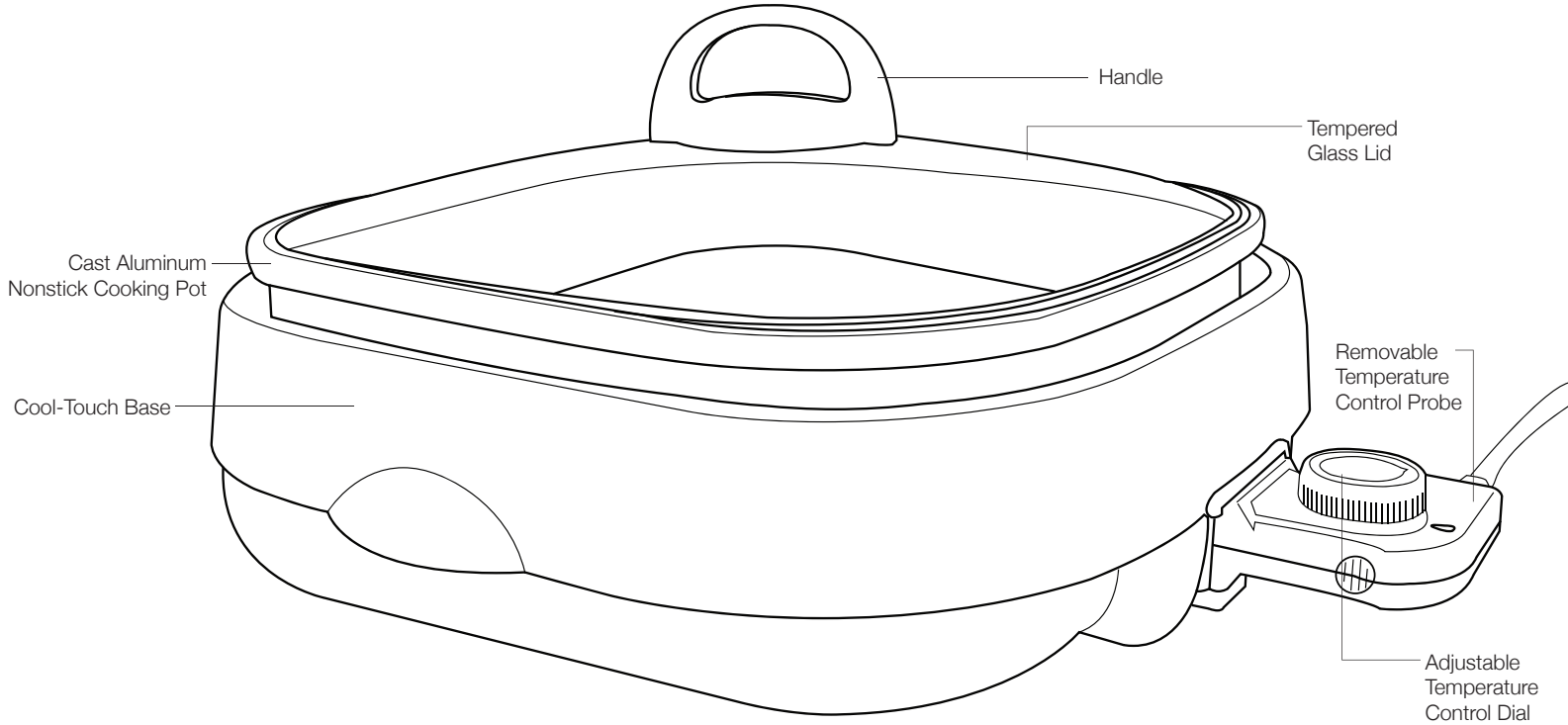



BEFORE FIRST USE

1. Please read all instructions and important safeguards.

2. Remove all packaging materials and check that all items have been received in good condition.
3. Tear up all plastic bags as they can pose a risk to children.
4. Pull the cooking pot away from the cool-touch base and wash the cooking pot, base and lid with warm, soapy water using a sponge or dishcloth.
5. Rinse the cool-touch base and lid thoroughly to remove all soap residue, wipe the cooking pot clean with a dry cloth.
6. Condition the nonstick surface of the cooking pan with oil or vegetable shortening.



CAUTION

- Do not clean with abrasive cleaners, metal scouring pads or products that are not considered safe to use on nonstick coatings.
- Do not wash or immerse cord or plug in water or any other liquid. The cord and plug are NOT dishwasher safe.



TO ASSEMBLE THE LID

The lid will require some assembly.

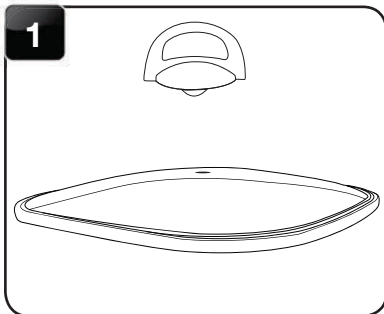

1 Locate the lid handle. The screw needed to assemble the lid handle to the lid will be screwed into the lid handle.

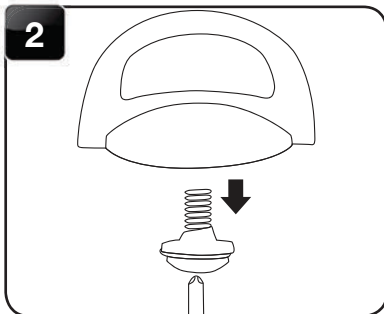

2 Using a Phillips-head screwdriver, unscrew the screw from the lid handle.

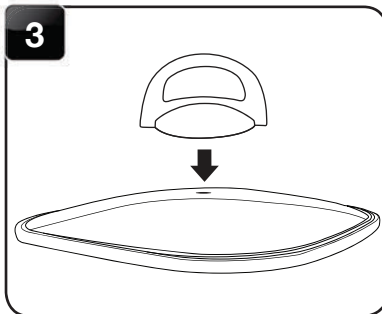

3 Place the lid handle on top of the lid, so that it lines up with the hole in the lid correctly.

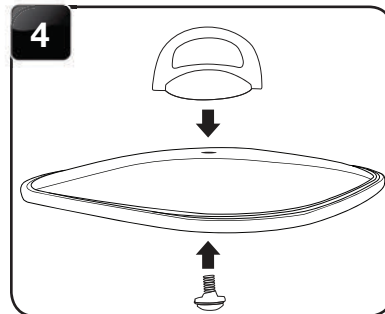

4 Place the screw beneath the lid so that it fits correctly through the hole in the lid and into the lid handle.

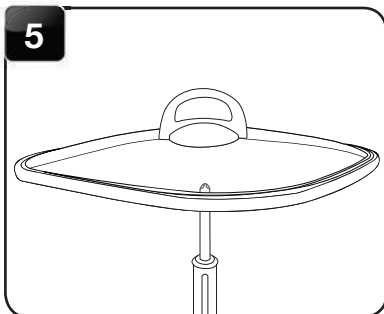

5 Using a Phillips-head screwdriver, tighten the screw until the lid handle is securely attached to the lid.



TO USE YOUR 3-in-1 Grillet™

1

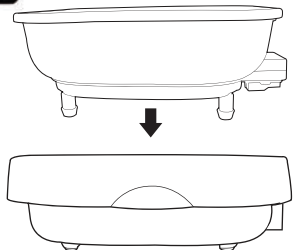

Place the cooking pot into the cool-touch base. It should snap securely into place.

2

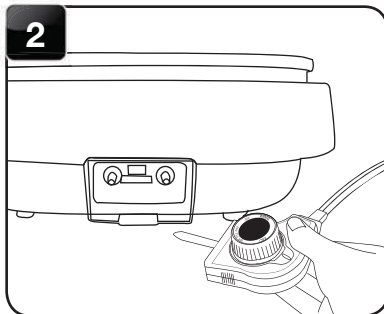

Plug the temperature control probe into the port in the cool-touch base.

3

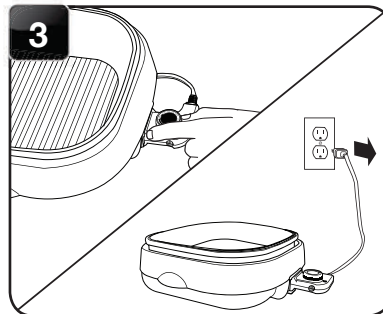

Turn the temperature control dial to the "OFF" position. Plug the power cord into an available power outlet.

4

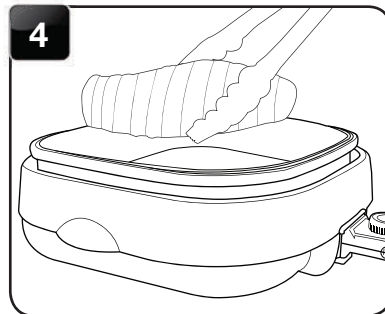

Add food to be cooked to the cooking pot. If desired, cover the pot with the tempered glass lid to help decrease cooking time and ensure even cooking.

5

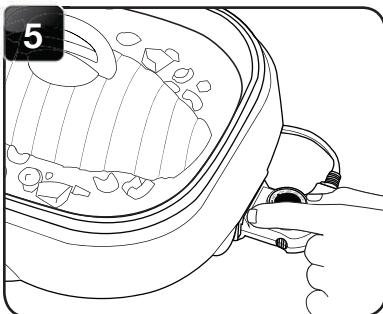

Turn the temperature control dial to the desired temperature. The indicator light will illuminate.

6

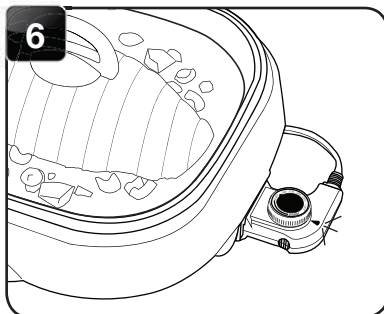

During operation, the indicator light will turn off and on once the selected temperature is reached to maintain temperature.

7

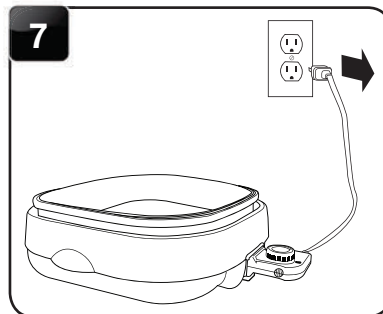

When cooking has finished, turn the temperature control dial to the "OFF" position and unplug the power cord from the power outlet.



NOTE

- Wooden, heat-proof plastic and nylon utensils are recommended. Metal utensils may scratch the nonstick surface.
- When slow cooking, simmering or steaming place the tempered glass lid on top of the 3-in-1 Grillet™.



CAUTION

- During and after use, the tempered glass lid and the nonstick pot will become very hot. Be sure to use the handle and wear protective oven mitts or gloves.
- To prevent food borne illness, always make sure food is cooked thoroughly before serving.



TO SLOW COOK or SIMMER

Follow Steps 1-3 from "To Use Your 3-in-1 Grillet™" on page 6.

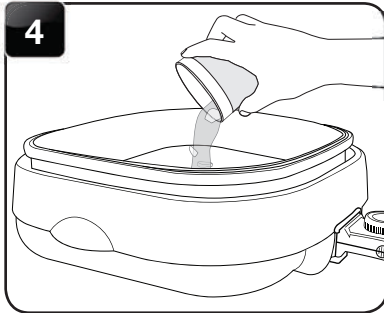

4 Place food inside the 3-in-1 Grillet™. Add one cup of liquid for each hour of cooking including any marinade. Place the tempered glass lid on top.

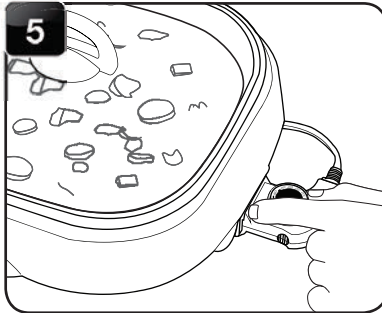

5 Turn the temperature control dial to 300° F. The indicator light will illuminate. When preparing soup or stew, allow extra time for it to simmer. This will allow flavors to fully blend and meat to become more tender.

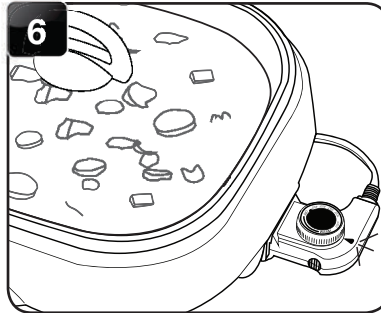

6 During operation, the indicator light will turn off and on once the selected temperature is reached to maintain temperature.

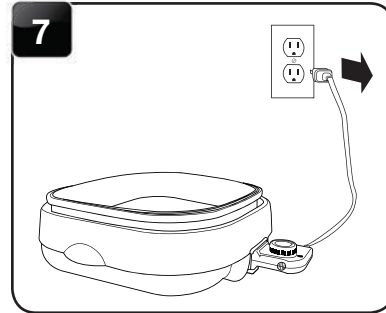

7 When cooking has finished, turn the temperature control dial to the "OFF" position and unplug the power cord from the power outlet.



NOTE

- The 3-in-1 Grillet™ functions similar to a high slow cooker. For all recipes, follow high slow cook instructions to ensure best results.



HELPFUL HINTS

- When adding liquid use half broth, half water for best flavor.
- To thicken stew, mix in ¼ cup of flour with enough water to form a thin paste. Gradually add it to the stew, stirring until thickened.
- If using fresh parsley or herbs in your recipe, add them in the last few moments of cooking to preserve flavor.
- Canned stew tomatoes or water with bouillon seasoning and spices added make great stock starters for soups and stews.



TO STEAM

Follow Steps 1-3 from "To Use Your 3-in-1 Grillet™" on page 6.

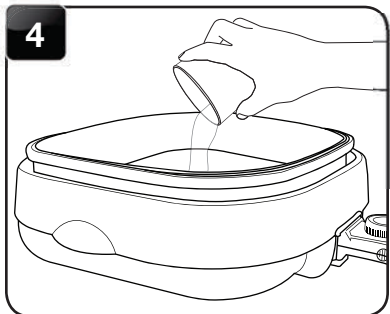

4 Place food on a heat-safe dish or metal rack that will fit inside the 3-in-1 Grillet™ with lid closed. Pour one cup of water (or more if needed) into the pot. Place food inside the cooking pot. Place the tempered glass lid on top.

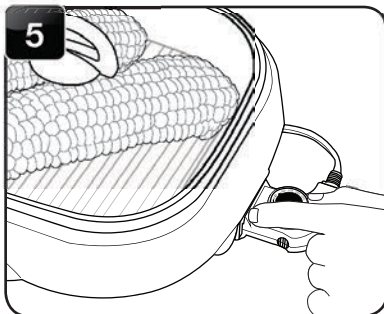

5 Turn the temperature control dial to a high setting. The indicator light will illuminate.

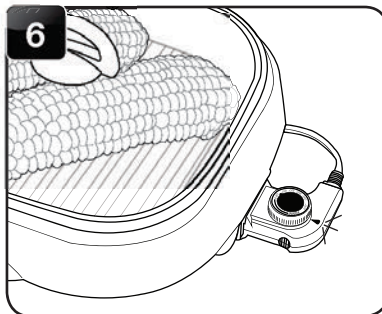

6 During operation, the indicator light will turn off and on once the selected temperature is reached to maintain temperature.

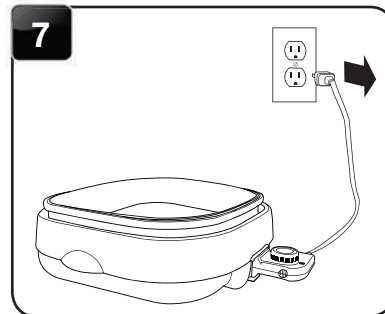

7 When steaming has finished, turn the temperature control dial to the "OFF" position and unplug the power cord from the power outlet.



NOTE

- Wooden, heat-proof plastic and nylon utensils are recommended. Metal utensils may scratch the nonstick surface.
- All vegetables should be thoroughly cleaned and washed before steaming. Thin, leafy vegetables such as cabbage do not require as much water as root vegetables, such as carrots.
- Do not remove lid during steaming, as steam will escape and the cooking time will be extended.
- Food can be placed directly on the grilled surface of the pot for steaming.



CAUTION

- During and after use, the glass cooking lid and the nonstick pot will become very hot. Be sure to use the handle and wear protective oven mitts or gloves.
- To prevent food borne illness, always make sure food is cooked thoroughly before serving.



STEAMING TABLES

FOOD	APPROXIMATE TIME
Asparagus	8-14 Minutes
Beef	18-26 Minutes
Broccoli	8-12 Minutes
Cabbage	12-18 Minutes
Carrots	12-18 Minutes
Cauliflower	12-18 Minutes
Chicken	17-20 Minutes
Corn (on the Cob)	14-18 Minutes
Crab Legs	14-20 Minutes

FOOD	APPROXIMATE TIME
Eggs	10-15 Minutes
Fish	12-18 Minutes
Green Beans	14-20 Minutes
Peas	8-12 Minutes
Pork	18-24 Minutes
Potatoes	24-40 Minutes
Rice	30-45 Minutes
Spinach	8-12 Minutes
Squash	16-30 Minutes
Zucchini	12-18 Minutes



NOTE

- The steaming times are approximate. Altitude, humidity, outside temperature and thickness and/or amount of food may affect cooking times.
- These charts are for reference only.



HELPFUL HINTS

- To ensure meat tastes its best, and to prevent possible illness, check that meat has reached its recommended safe temperature prior to serving.



TO CLEAN

Always unplug the unit and allow it to cool completely before cleaning.

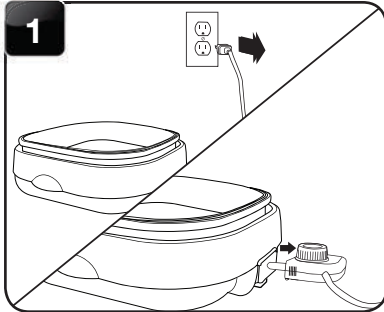

1 Disconnect the plug from the wall outlet, and then remove the temperature control probe from the appliance.

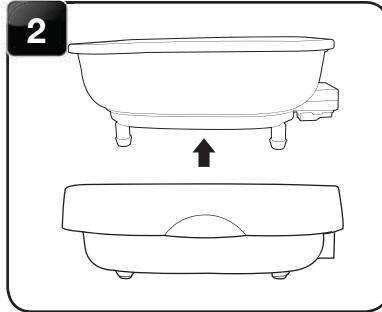

2 Allow the unit to completely cool. Pull the cooking pot away from the cool-touch base.

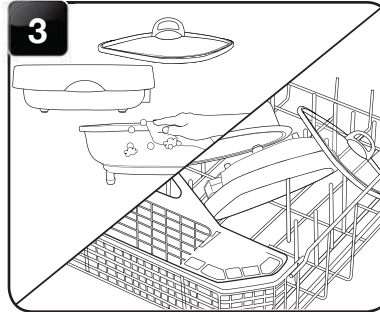

3 Wash the cooking pot, base and lid with warm, soapy water, using a sponge or dishcloth. Rinse thoroughly to remove soap residue. For faster cleanup, the cool-touch base and lid can be washed in the dishwasher.

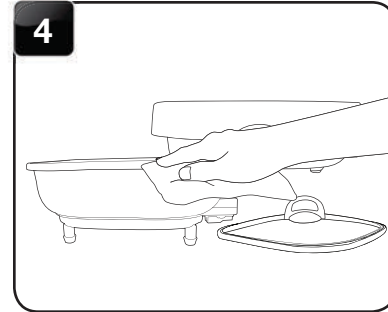

4 Dry thoroughly with a soft cloth.



NOTE

- Do not clean with abrasive cleaners, metal scouring pads or products that are not considered safe to use on nonstick coatings.
- Do not wash or immerse cord or plug in water or any other liquid. The cord and plug are NOT dishwasher safe.
- Do not immerse the cooking pot in water or any liquid.
- Any other servicing should be performed by Aroma® Housewares. Contact Aroma® customer service at 1-800-276-6286, Monday to Friday 8:30AM-4:30PM PST.



TROUBLESHOOTING

Below is a troubleshooting tip to help you achieve the desired consistency.

PROBLEM	POTENTIAL CAUSES	SOLUTIONS
The 3-in-1 Grillet™ will not turn on and begin heating.	The temperature probe is not securely connected to the pot.	Make sure the temperature probe is pushed firmly into the port on the cool-touch base. If the problem persists, please contact Aroma® customer service toll-free at (800) 276-6286 or through email at CustomerService@AromaCo.com for repair service.



RECIPES

Aroma's Favorite BBQ Chicken

Ingredients

4	chicken breasts
½ cup	butter or margarine
¾ cup	lemon juice
2 teaspoons	garlic salt
2 tablespoons	cumin
2 tablespoons	cayenne pepper
1 teaspoon	salt
½ teaspoon	pepper

Set the 3-in-1 Grillet™ temperature to 300°F and melt the butter in the pot. Add lemon juice, garlic salt, cumin and cayenne pepper to the pot. Pour ½ of this marinade into a large bowl. Pierce the chicken in several places and sprinkle with salt and pepper. Place the chicken in the bowl with the marinade, turning occasionally to coat the chicken. Turn the 3-in-1 Grillet™ temperature to 375°F. Place the chicken into the pot, brushing with the reserved marinade. Grill, turning and basting the chicken with the marinade occasionally, until the chicken is thoroughly cooked (about 15 minutes).

Beef Stew

Ingredients

4 cups	water
5 cubes	beef bouillon
1 teaspoon	Worcestershire sauce
2 cups	cooked beef, cubed
6	carrots, peeled and cut into chunks
1 medium	onion, chopped
2 tablespoons	flour
1	garlic clove, minced
1 small	bay leaf
-	dash pepper

Set the 3-in-1 Grillet™ temperature to 350°F. Add water and bouillon cubes to the pot and bring to a boil until the bouillon cubes completely dissolve. Add Worcestershire sauce and a dash of pepper to the pot. Add beef, carrots and garlic to the pot and stir until the sauce begins to boil, adjusting the temperature if necessary. Place the bay leaf on top, then cover with the lid and reduce heat.

Simmer for about 30 minutes or until the vegetables become tender. Pour about ½ of the liquid into a small bowl and blend with flour. Increase the temperature of the pot again to bring the stew to a boil. Slowly add the flour mixture to the stew and stir continuously until the stew thickens. Remove the bay leaf and serve.



RECIPES (CONT.)

Classic Casserole

Ingredients

2	yukon gold potatoes, peeled and diced
2	sweet potatoes, peeled and diced
¼ cup	panko bread crumbs
16 ounces	your favorite cooked sausage, diced
1	green zucchini, diced
1	yellow onion, diced
1	green bell pepper, diced
1	mild green chili pepper, diced
1 cup	shredded mozzarella cheese
2 tablespoons	olive oil

Steam the potatoes in the 3-in-1 Grillet™ for 10 minutes. Remove from the pot and then cook the sausage until brown. Remove the sausage from the 3-in-1 Grillet™ and set aside. Add olive oil, onion, peppers, zucchini and cook until browned. Add potatoes and sausage and 1 cup of water. Let cook on high heat until most liquid has evaporated. Sprinkle with panko and cheese and let steam under the lid for 5 minutes or so before serving.

Smothered Pork Chops

Ingredients

6	pork chops, ½-inch thick (center cut or boneless)
1 tablespoon	corn starch
1 can	beef broth
⅛ teaspoon	pepper
2 tablespoons	butter
1 medium	onion, sliced

Mix starch, broth and pepper. Melt butter in 3-in-1 Grillet™ and sauté chops, cooking until browned. Remove chops and set aside. Add onion (add extra butter if needed) and cook until tender-crisp. Add broth mixture. Cook until mixture boils and thickens, stirring. Return chops to pot. Cover and cook over low heat 5 minutes or until done.



WARRANTY

LIMITED WARRANTY

Aroma Housewares Company warrants its products against defects in material and workmanship for two years from provable date of purchase in the United States.

Within this warranty period, Aroma Housewares Company will repair or replace, at its discretion, defective parts at no charge, provided the product is returned, freight prepaid with proof of purchase and U.S. \$20.00 for shipping and handling charges payable to Aroma Housewares Company. Before returning an item, please call the toll free number below for a return authorization number. Allow 2-4 weeks for return shipping.

This warranty does not apply if the warranty period expired; the products has been modified by any unauthorized service center or personnel; the defect was subject to abuse, improper use not conforming to product manual instructions, or environment conditions more severe than those specified in the manual and specification, neglect of the owner or improper installation; the defect was subject to Force Majeure such as flood, lightning, earthquake, other natural calamities, war, vandalism, theft, brownouts or sags (damage due to low voltage disturbances).

This warranty gives you specific legal rights, which may vary from state to state, and does not cover areas outside the United States.

AROMA HOUSEWARES COMPANY
6469 Flanders Drive
San Diego, California 92121
1-800-276-6286
M-F, 8:30 AM - 4:30 PM, Pacific Time
Website: www.AromaCo.com

SERVICE & SUPPORT

In the event of a warranty claim, or if service is required for this product, please contact Aroma® customer service toll-free at:

1-800-276-6286
M-F, 8:30AM-4:30PM, Pacific Time

Or we can be reached online at CustomerService@AromaCo.com.

For your records, we recommend stapling your sales receipt to this page along with a written record of the following:

Date of Purchase: _____

Place of Purchase: _____



NOTE

- Proof of purchase is required for all warranty claims.